





Licensed by Carrier Corporation



Energy optimization solutions

COOLtec[®] EB CO₂ Efficiency Booster Skid



 **20–540 kW** MT cooling capacity
 **3–200 kW** LT cooling capacity



Up to 10% energy savings



Sizes available to cover all capacities



Very compact: < 1 m² footprint



From 1 to 3 years pay back time



Add-on module with existing racks*



Easy to connect on site



Increased cooling capacity 5 to 15%



Compatible with multiple controllers



60 bar stand still pressure design

Brochures

*Contact our sales team for compatibility check



Add-on module to boost energy efficiency and reduce electrical consumption up to 10% of CO₂ traditional booster systems (with and without eco compressor). Cabinets and cold room evaporators can run in optimized semi-flooded mode, increasing efficiency and reducing defrost time.

MT MODULE	Cooling capacity*		Dimensions (mm)	Weight (kg)	Suction line connection
	Min (kW)	Max (kW)			
CEB KIT MT 50	20	70	700 x 880 x 1380	155	1"1/8
CEB KIT MT 80	70	115	700 x 880 x 1400	240	1"3/8
CEB KIT MT 80 DUO**	70	115	700 x 950 x 1400	270	1"3/8
CEB KIT MT 100	115	170	700 x 900 x 1660	260	1"5/8
CEB KIT MT 100 DUO**	115	170	700 x 950 x 1660	290	1"5/8
CEB KIT MT 170	170	540	700 x 1020 x 1980	360	1"1/8
CEB KIT MT 170 DUO**	170	540	700 x 1020 x 1980	390	1"1/8

* @ -5°C / 38°C / 94 bar. Contact our sales team for selection

** CEB DUO (liquid & vapor ejector) for new rack orders with Danfoss controller

MT MODULE	Cooling capacity*		Dimensions (mm)	Weight (kg)	Suction line connection
	Min (kW)	Max (kW)			
CEB KIT LT 18	20	57	700 x 910 x 1420	100	1"1/8
CEB KIT LT 36	57	86	700 x 910 x 1420	125	1"3/8
CEB KIT LT 99	86	210	700 x 990 x 1610	190	2"1/8

* @ -32°C / -5°C. Contact our sales team for selection

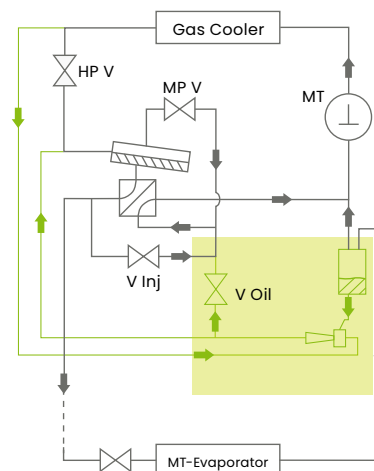

Key features:

- Suction accumulator to prevent liquid from going to compressors
- Liquid ejector to return liquid to main receiver for MT modules.
- Liquid / gas heat exchanger for LT modules
- Liquid levels for control and safety
- Oil return line
- Suction line bypass for easier service
- Bypass for easy maintenance and start up
- Dual safety valves 60 bar for MT and 30 bar for LT ready for connection
- Compatible for Danfoss & Eckelmann

Options:

- Danfoss or Eckelmann retrofit kits for existing racks
- extra cable length to suit all configurations
- 52 or 45 bar (MT) / 25 bar (LT) safety valves to comply with existing rack
- Vapor ejector for rack with eco - compressors

Welcome to the Climate Control Revolution



CCR reserves the right to change certain information and specifications contained in this document at any time and without prior notice. Since standards, specifications and designs are subject to occasional change, please ask for confirmation of the information given in this publication.

www.ccr.com

